

TfxEcho

TimeFX Echo

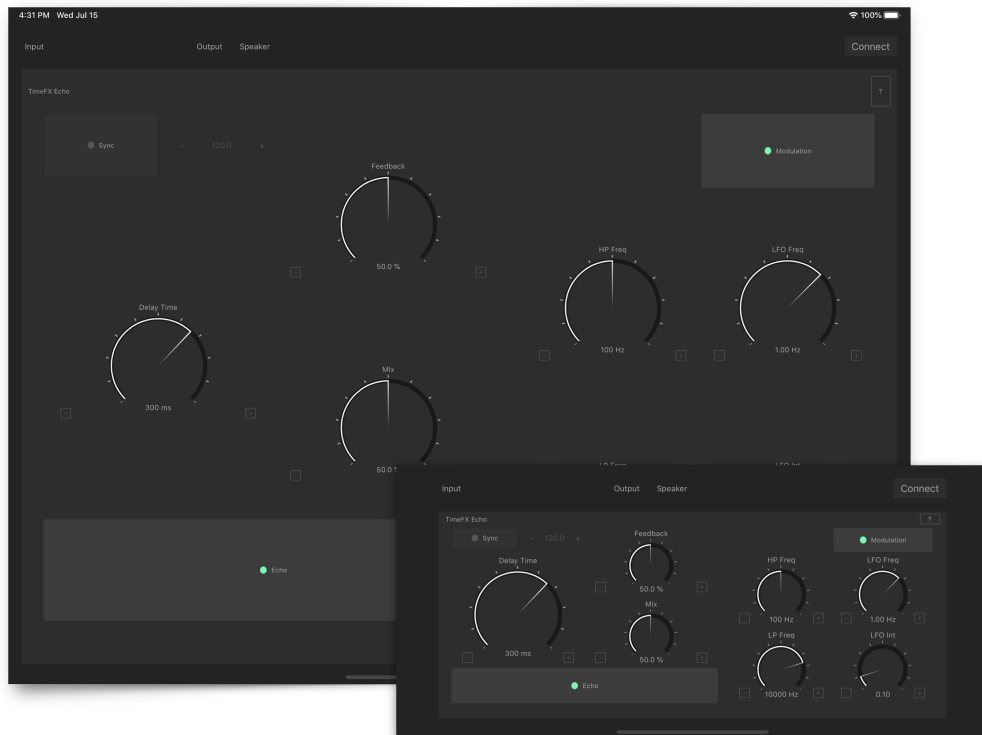

User Guide

Version 1.5

Table of Contents

Introduction	4
Features	4
User Interface	5
Host Application	5
1. Audio Input Source Label	5
2. Audio Output Source Label	5
3. Connect button	5
AudioUnit Extension	5
4. Sync Switch	5
5. Tempo	5
6. Delay Time	6
7. Feedback	6
8. Mix	6
9. Effect Switch	6
10. High-pass filter Frequency	6
11. Lowpass filter Frequency	6
12. Modulation Switch	6
13. LFO Frequency	6
14. LFO Intensity	6
15. Help Button	6
Host Application	7
How to enable / disable effect unit	7
Permission to access microphone	7
Feedback Loop	7
AudioUnit Extension	8
Signal Flow	8
Operation	8
Delay Time	8
Regeneration	8

Modulation	8
Mlx	8
Dial UI: Fine Adjustment and Reset	8
Specification	9
What's new in version 1.0	9
What's new in version 1.1	9
What's new in version 1.2	9
What's new in version 1.3	9
What's new in version 1.4	9
What's new in version 1.5	9

Introduction

Thank you for purchasing TfxEcho. To help you get the most out of this product, please read this manual carefully.

TfxEcho is an echo effect AudioUnit Extension plugin. It uses delay lines which are inspired by BBD (bucket brigade device). BBD is used in various analog delay unit and is known for its warm and dark sound. The delay line uses fixed length buffer and an artificial clock to sample input signal in variable sampling rate. When the delay time is changed, the delay line can produce pitch change effect which is similar to the behavior of the BBD based analog delay unit.

The delay line is inspired by BBD, but it is not emulation of the any particular BBD. Unlike the typical BBD based delay unit, frequency range of the delay line is not limited. The delay line is capable to capture signal in higher frequency up to about 22KHz.

Features

AudioUnit Extension

Delay Time: From 20 ms to 1200 ms

Feedback: From 0 % to 100 %

Adjustable lowpass filter and high-pass filter.

Modulation rate: From 0.01 Hz to 10 Hz

Modulation width: From 0 ms to +/- 10 ms

Delay time can be synced to tempo provided by the host application.

Host Application

Host application uses system audio input as an audio source and processed audio signal is routed to the system audio output.

User Interface



Host Application

1. Audio Input Source Label

Display a name of the Audio input source

2. Audio Output Source Label

Display a name of the audio output source

3. Connect button

Tap this button to enable / disable connection from audio input source to AUv3 Extension.

AudioUnit Extension

4. Sync Switch

Tap this button to enable / disable MIDI tempo sync

5. Tempo

Shows value of the tempo provided by the host application. If the host application don't provide tempo, value of tempo can be adjusted manually by + and - buttons.

6. Delay Time

Adjust delay time.

7. Feedback

Adjust amount of the feedback.

8. Mix

Adjust amount of the delayed signal mixed with the original signal.

9. Effect Switch

Tap this button to turn on or turn off (bypass) the effect.

10. High-pass filter Frequency

Adjust frequency of the high-pass filter.

11. Lowpass filter Frequency

Adjust frequency of the lowpass filter.

12. Modulation Switch

Tap this button to enable / disable modulation.

13. LFO Frequency

Adjust frequency of the LFO.

14. LFO Intensity

Adjust intensity of the modulation.

15. Help Button

Tap this button to show user guide.

Host Application

Host application uses system audio input as an audio source and processed audio signal is routed to the system audio output.

How to enable / disable effect unit

1. Tap connect button to enable / disable connection from audio input source to AUv3 Extension.

Permission to access microphone

When application is launched at the first time, it will ask permission to use built-in microphone. If the permission is denied, application can't access to audio input source.

If you wish to set the permission manually, change preference under Settings -> Privacy -> Microphone.

Feedback Loop

When audio input source is built-in microphone and audio output source is built-in speaker, connection from audio input source to AudioUnit Extension is disconnected to prevent audio feedback loop. If you want use built-in microphone as an audio input source, please connect headphone or line out.

AudioUnit Extension

Signal Flow

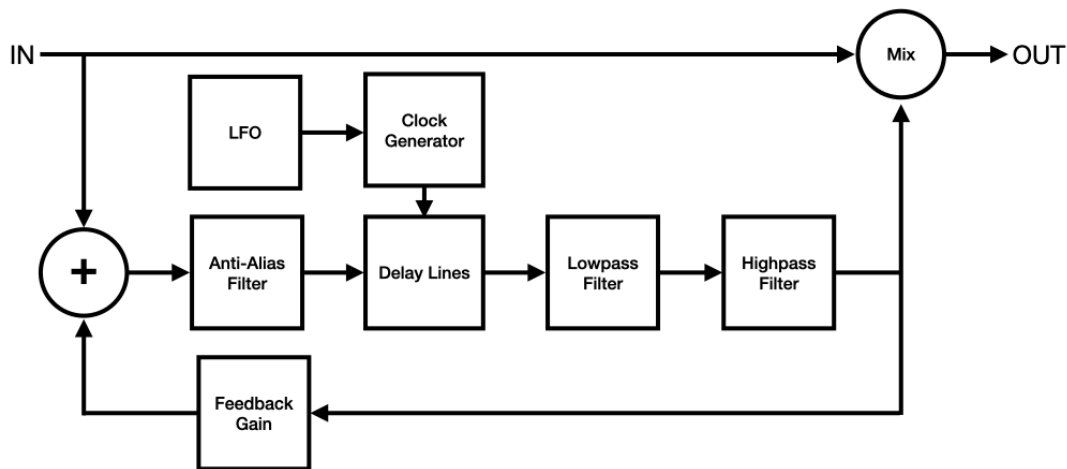

Operation

Delay Time

Adjust delay time from 20 ms to 1200 ms. When sync switch is turned on, delay time can be set as note value which is synchronized to the tempo provided by the host application. If tempo is not provided by the host application, value of the tempo can be manually adjusted. Valid range of the note value is automatically adjusted base on the current tempo.

Regeneration

Adjust feedback from 0 % to 100 %. Be careful when using feedback amount more than 70 %, sound can be build up very quickly. You can change sound of the feedback by adjusting frequency of the high-pass filter and the low-pass filter.

Modulation

When modulation switch is turned on, modulation can be applied to the delayed signal. LFO (Low Frequency Oscillator) generates sine wave for the modulation.

Adjust LFO frequency from 0.01 Hz to 10 Hz.

Adjust LFO Intensity from 0 to 1.0, which adjust modulation width from 0 ms to +/- 10 ms.

Mix

Adjust balance of the direct sound and delayed sound from 0 % (Dry) to 100 % (Wet).

Dial UI: Fine Adjustment and Reset

Use + and - buttons to adjust parameter values. Double tap on dial UI resets the dial to the default position.

Specification

Delay Time	Range from 20ms to 1200ms
Feedback	Range from 0% to 100%
Mix	Range from 0% to 100%
Highpass Filter	Range from 20Hz to 500Hz
Lowpass Filter	Range from 1000Hz to 20000Hz
LFO Frequency	Range from 0.01Hz to 10Hz
LFO Intensity	Range from 0.0 to 1.0 (from 0ms to +/- 10ms)
Effect Switch	ON or OFF
Sync Switch	ON or OFF
Modulation Switch	ON or OFF
Frequency Range	From 0Hz to 22.05KHz (effect)

What's new in version 1.0

- Initial release

What's new in version 1.1

- Limiter is inserted in feedback loop to prevent delay lines from blowing up.

What's new in version 1.2

- Fixed distortion caused by large amount of feedback.
- Fixed click noise caused by turning effect button on or off.

What's new in version 1.3

- Fixed a problem in initialization process of AudioUnit Extension which may leads the AudioUnit Extension to crash or may leads state recovery to fail.

What's new in version 1.4

- Support iOS 14 / iPadOS 14.

What's new in version 1.5

- Support iOS 15 / iPadOS 15.