

# TfxReverb

## TimeFX Reverb

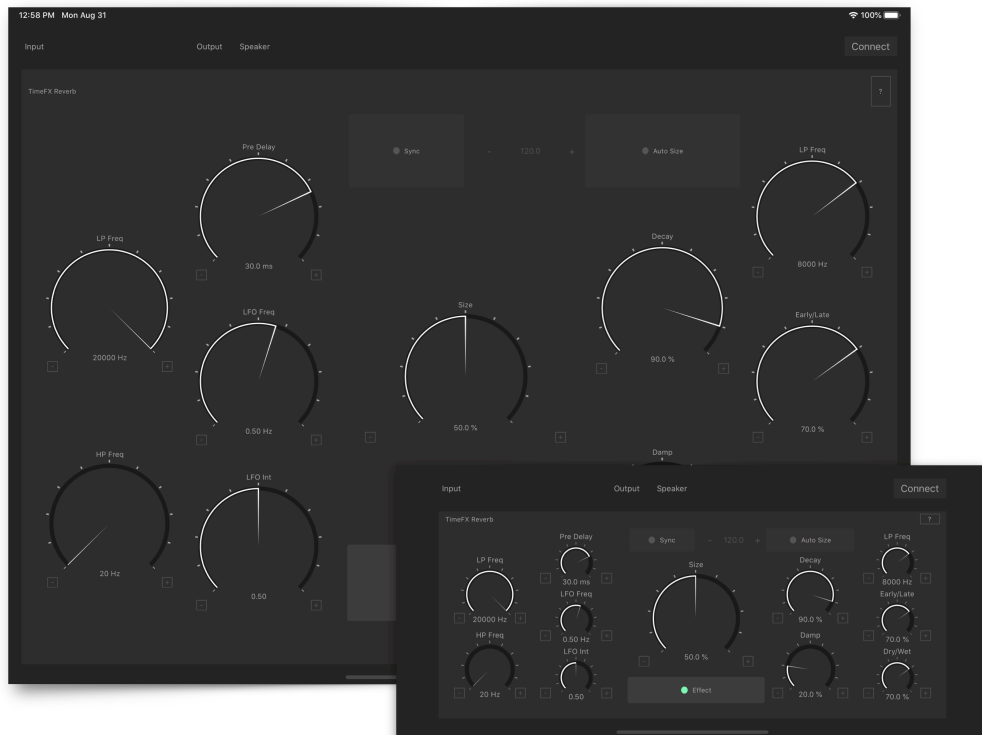

## User Guide

Version 1.1

# Table of Contents

Introduction	4
Features	4
User Interface	5
Host Application	5
1. Audio Input Source Label	5
2. Audio Output Source Label	5
3. Connect button	5
AudioUnit Extension	5
4. Sync Switch	5
5. Tempo	5
6. Input Lowpass Filter Frequency	6
7. Input High-pass Filter Frequency	6
8. Pre Delay Time	6
9. LFO Frequency	6
10. LFO Intensity	6
11. Size	6
12. Auto Size	6
13. Decay	6
14. Damp	6
15. Output Lowpass Filter Frequency	6
16. Early/Late Mix	6
17. Dry/Wet Mix	6
18. Effect Switch	6
19. Help Button	7
Host Application	8
How to enable / disable effect unit	8
Permission to access microphone	8
Feedback Loop	8
AudioUnit Extension	9

Signal Flow	9
Operation	9
Input Filter	9
Pre Delay	9
Modulation Speed	9
Modulation Width	9
Size and Decay	9
Damping	10
Output Filter	10
Early / Late Mix	10
Dry / Wet Mix	10
Effect Switch	10
Dial UI: Fine Adjustment and Reset	10
Specification	11
What's new in version 1.0	11
What's new in version 1.1	11

# Introduction

Thank you for purchasing TfxReverb. To help you get the most out of this product, please read this manual carefully.

TfxReverb is a reverb effect AudioUnit Extension plugin. It uses algorithm to generate digital reverb sound. TfxReverb is designed for simple and easy operation. When auto size mode is enabled, number of parameters can be controlled by a single dial to adjust size of the reverb sound, which can be synced to tempo.

It features delay lines which are inspired by BBD (bucket brigade device). The delay line uses fixed length buffer and an artificial clock to sample input signal in variable sampling rate. When the delay time is changed, the delay line can produce pitch change effect which is similar to the behavior of the BBD based unit.

## Features

### AudioUnit Extension

Input lowpass filter: From 1KHz to 20KHz  
Input high-pass filter: From 20Hz to 500Hz

LFO Frequency: From 0.01Hz to 10Hz  
LFO Intensity: From 0.0 to 1.0

Pre Delay: From 1ms to 100ms

Size: From 0% to 100%  
Auto size mode: On / Off

Decay: From 0% to 100%  
Damp: From 0% to 100%

Output Lowpass Filter: From 1KHz to 20KHz  
Early/Late Mix: From 0% to 100%  
Dry/Wet Mix: From 0% to 100%

Tempo Sync: On / Off  
Tempo (manual) : From 1bpm to 999bpm

Effect Switch: On / Off

### Host Application

Host application uses system audio input as an audio source and processed audio signal is routed to the system audio output.

# User Interface

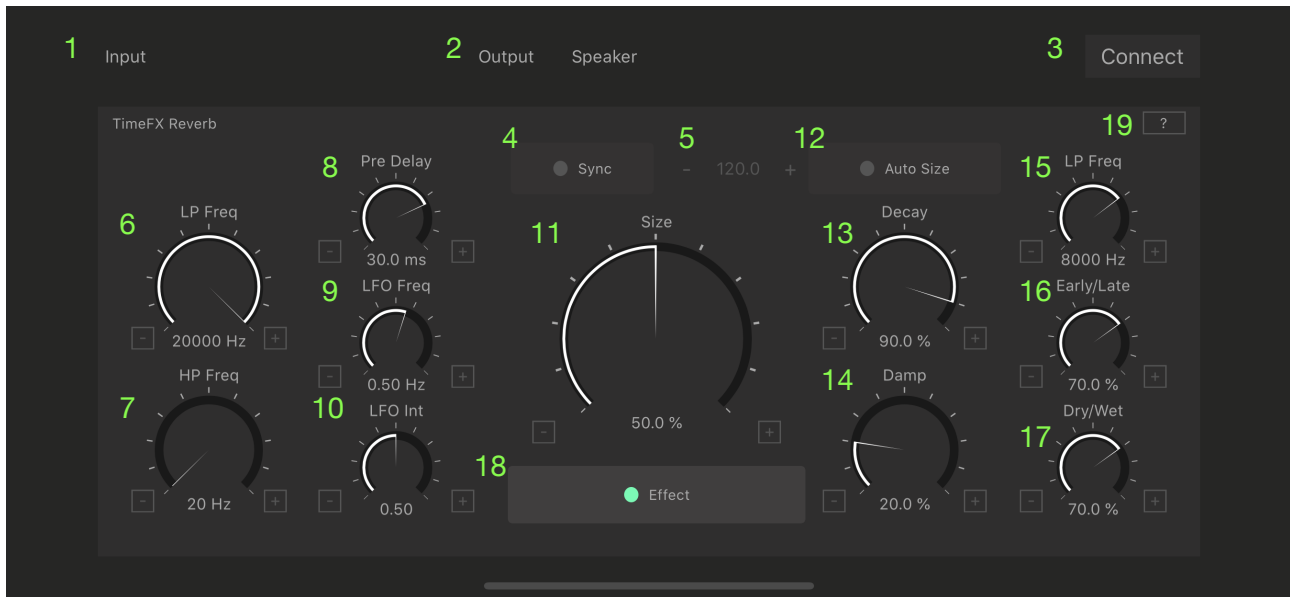

## Host Application

### 1. Audio Input Source Label

Display a name of the Audio input source

### 2. Audio Output Source Label

Display a name of the audio output source

### 3. Connect button

Tap this button to enable / disable connection from audio input source to AUv3 Extension.

## AudioUnit Extension

### 4. Sync Switch

Tap this button to enable / disable MIDI tempo sync

### 5. Tempo

Shows value of the tempo provided by the host application. If the host application don't provide tempo, value of tempo can be adjusted manually by + and - buttons.

---

## 6. Input Lowpass Filter Frequency

Adjust frequency of the input low-pass filter.

---

## 7. Input High-pass Filter Frequency

Adjust frequency of the input high-pass filter.

---

## 8. Pre Delay Time

Adjust pre delay time of the early reflection.

---

## 9. LFO Frequency

Adjust frequency of the LFO to control speed of the modulation.

---

## 10. LFO Intensity

Adjust intensity (width) of the modulation.

---

## 11. Size

Adjust room size of the late reflection.

---

## 12. Auto Size

Tap this button to turn on/off auto size mode.

---

## 13. Decay

Adjust decay of the late reflection.

---

## 14. Damp

Adjust absorption of high frequency in the late reflection.

---

## 15. Output Lowpass Filter Frequency

Adjust frequency of the output low-pass filter.

---

## 16. Early/Late Mix

Adjust amount of the early reflection and the amount of the late reflection.

---

## 17. Dry/Wet Mix

Adjust amount of the effect signal mixed with the dry signal.

---

## 18. Effect Switch

Tap this button to turn on or turn off (bypass) the effect.

---

## 19. Help Button

Tap this button to show user guide.

## **Host Application**

Host application uses system audio input as an audio source and processed audio signal is routed to the system audio output.

## **How to enable / disable effect unit**

1. Tap connect button to enable / disable connection from audio input source to AUv3 Extension.

## **Permission to access microphone**

When application is launched at the first time, it will ask permission to use built-in microphone. If the permission is denied, application can't access to audio input source.

If you wish to set the permission manually, change preference under Settings -> Privacy -> Microphone.

## **Feedback Loop**

When audio input source is built-in microphone and audio output source is built-in speaker, connection from audio input source to AudioUnit Extension is disconnected to prevent audio feedback loop. If you want use built-in microphone as an audio input source, please connect headphone or line out.



# AudioUnit Extension

## Signal Flow

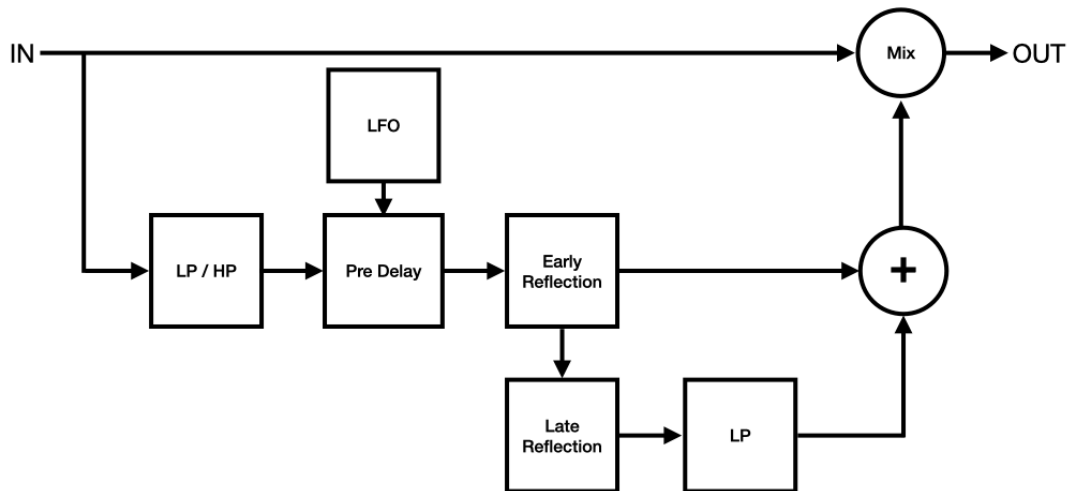

## Operation

---

### Input Filter

Use Lowpass filter and high-pass filter to attenuate high frequency and low frequency of the input signal.

---

### Pre Delay

Use pre delay to adjust amount of the time between the direct signal and beginning of the early reflection signal. This parameter can be used to express size of the space. Reflection takes short time to bounce back in small room and it takes long time in large room. Also this parameter can be used to separate dry signal and reverb signal in the mix.

---

### Modulation Speed

LFO Frequency dial controls speed of the modulation. When sync switch is turned on, LFO Frequency can be set as note value which is synchronized to the tempo provided by the host application. If tempo is not provided by the host application, value of the tempo can be manually adjusted. Valid range of the note value is automatically adjusted base on the current tempo.

---

### Modulation Width

LFO Intensity dial controls width of the modulation and pre delay time dial controls center position of the modulation. Range of the LFO intensity is from 0 ms to +/- 10 ms.

---

### Size and Decay

Size dial controls reverb time of late reflection and decay dial controls length of the reverb tail. Decay time can be used to express size of the space and material of the surface. Reflective materials, such as concrete or hardwood, gives longer decay time.

When sync switch is turned on, total reverb length, which can be controlled by pre delay, size and decay, is adjusted by note value which is synchronized to the tempo.

When auto size switch is turned on, size dial controls value of the parameters including size, pre delay, decay, damp, output LP frequency, early/late mix and dry/wet mix.

---

## Damping

Damp dial controls amount of high frequency absorption for the late reflection signal. Low damping values produce brighter reverb sound and high damping values produces darker reverb sound.

---

## Output Filter

Use lowpass filter to cut high frequency of the reverb signal.

---

## Early / Late Mix

Adjust balance of the early reflection signal and late reflection signal from 0% (early reflection ) to 100% (late reflection).

---

## Dry / Wet Mix

Adjust balance of the direct sound and delayed sound from 0% (Dry) to 100% (Wet).

---

## Effect Switch

Tap effect button to turn on or turn off (bypass) the effect.

---

## Dial UI: Fine Adjustment and Reset

Use + and - buttons to adjust parameter values. Double tap on dial UI resets the dial to the default position.

# Specification

Input lowpass filter	Range from 1KHz to 20KHz
Input high-pass filter	Range from 20Hz to 500Hz
LFO Frequency	Range from 0.01Hz to 10Hz
LFO Intensity	Range from 0.0 to 1.0
Pre Delay	Range from 1ms to 100ms
Size	Range from 0% to 100%
Auto Size Mode	ON or OFF
Decay	Range from 0% to 100%
Damp	Range from 0% to 100%
Output Lowpass Filter	Range from 1KHz to 20KHz
Early/Late Mix	Range from 0% to 100%
Dry/Wet Mix	Range from 0% to 100%
Tempo Sync	ON or OFF
Tempo (manual)	Range from 1 bpm to 999 bpm
Effect Switch	ON or OFF

## What's new in version 1.0

- Initial release

## What's new in version 1.1

- Support iOS 14 / iPadOS 14.